



Transparency Act Statement 2025

[Start reading](#)

CONTENTS

1. Prosafe and the Transparency Act	3	4. Human Rights-related risks within Supply Chain	6
1.1 Reporting under the Transparency Act	3	4.1 Supplier Due Diligence	6
2. Organisation and area of operations	3	4.3 Risk Assessment	6
2.1 Prosafe's commitment to Human Rights	3	5. Human Rights due diligence within Prosafe	8
3. Human Rights-related risks in Prosafe's operations	4	5.1 Guidelines and routines for handling Human Rights due diligence	8
3.1 Risk of negative consequences for Human rights and Labour Standards	4	5.2 Improving the identification of Human Rights risks within Supply Chain	9
3.2 Diversity and Equality	5	5.3 Human Rights protections in contract terms and conditions	9
		5.4 Incident reporting	9
		5.5 Response to Human Rights or Labour Standards violations	9

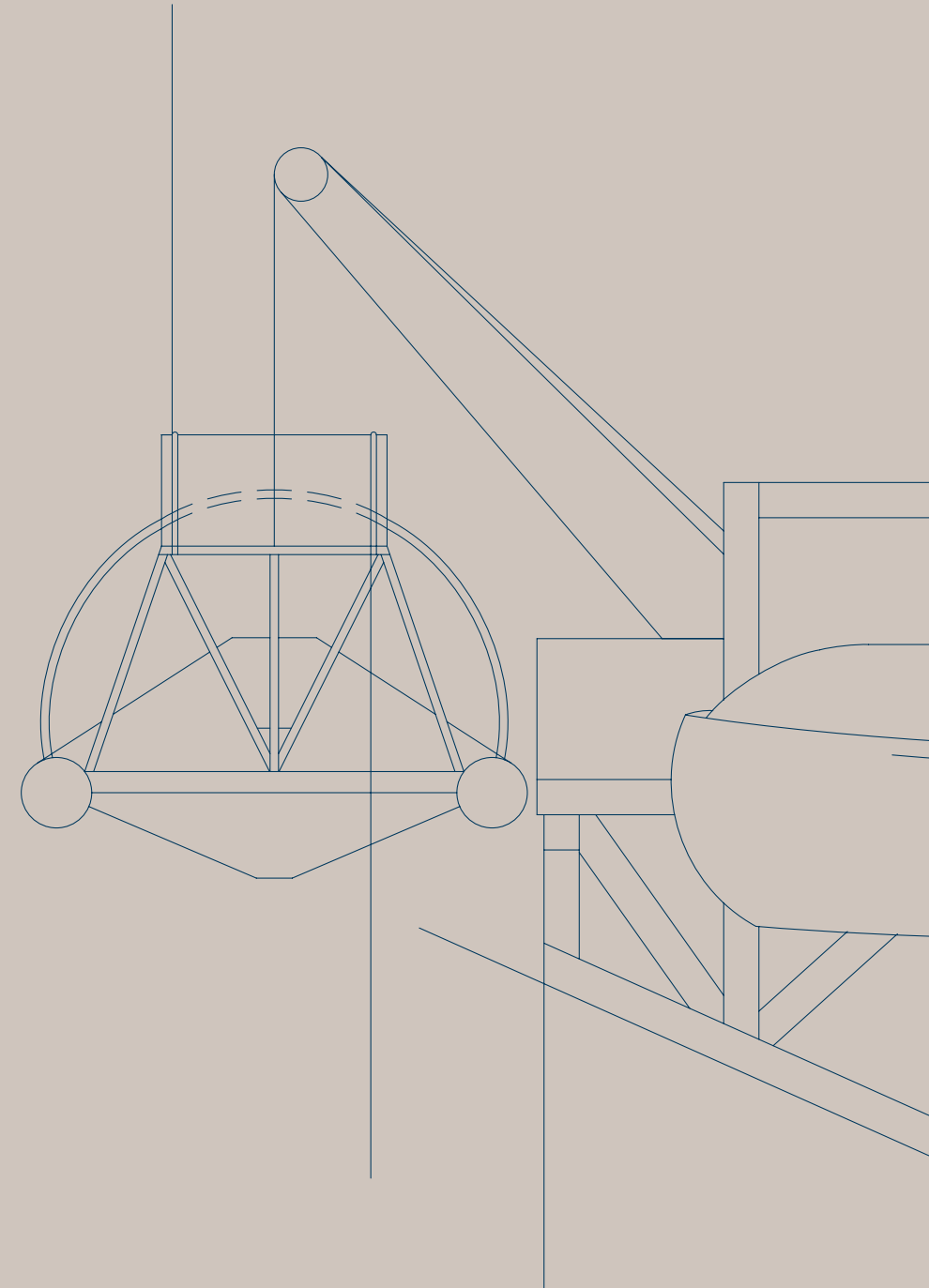

The following is the annual account of due diligence activities for the reporting period pursuant to Sections 4 and 5 of the Transparency Act¹.

1. Prosafe and the Transparency Act

Prosafe is committed to the highest standards of business ethics and shall comply with all applicable laws, including the Norwegian Transparency Act and the UK Modern Slavery Act, regulations and the Company's policies and procedures.

To meet the requirements of the Transparency Act, Prosafe endeavours to ensure that its Health, Safety, Security, Environmental, Quality (HSSEQ) and Corporate Social Responsibility (CSR) principles, including those relating to conflicts of interest, Anti-corruption, Human Rights, and Labour Standards are integrated in our operations and those of our Supply Chain.

The information of this report is valid for Prosafe SE and its consolidated subsidiaries, these include, but are not limited to Prosafe AS, Prosafe Holding AS, Prosafe Offshore Ltd, Prosafe Offshore Pte Ltd and Prosafe Rigs Pte Ltd.

1.1 Reporting under the Transparency Act

The Norwegian Transparency Act came into force on 1 July 2022. The Act established legal requirements for larger enterprises' duty to report on Human Rights due diligence, and their work to ensure compliance with fundamental Human Rights and decent working conditions within the enterprises, in their Supply Chains, and with their business partners.

The Transparency Act aims to promote enterprises' respect for fundamental Human Rights and decent working conditions and ensure that consumers, organisations, trade unions, journalists and the general public have access to information.

2. Organisation and area of operations

Prosafe is a leading owner and operator of offshore accommodation and units for safety and maintenance vessels. The Prosafe group consists of the Norwegian parent company, Prosafe SE, which is listed on the Oslo Stock Exchange, and a number of wholly owned subsidiaries.

Prosafe is headquartered in Oslo, Norway and has offices in Aberdeen (Scotland), Rio de Janeiro (Brazil) and Singapore. Prosafe's vessels can operate in most offshore environments, but our principal operations are in Brazil, the North Sea (United Kingdom) and Australia.

The ultimate responsibility for complying with the Transparency Act and Human Rights lies with Prosafe's Board of Directors.

More information can be found on www.prosafe.com

2.1 Prosafe's commitment to Human Rights

Prosafe acts in accordance with internationally recognised Human Rights and Labour Standards, including the International Bill of Human Rights, the United Nations Guiding principles on

¹ Lov om virksomheters åpenhet og arbeid med grunnleggende menneskerettigheter og anstendige arbeidsforhold (åpenhetsloven) 2022

Business and Human Rights, the ten principles of the UN Global Compact and the principles concerning fundamental rights set out in the International Labour Organisation's (ILO) Declaration on Fundamental Principles and Rights at Work.

The Company endeavours to ensure that its operations and those of its suppliers and partners are conducted in accordance with basic Human Rights standards. This statement of support can also be found in Prosafe's CSR Policy and in Prosafe's Code of Conduct².

Prosafe has a stand-alone Human Rights Policy³, anchored in our existing commitment to respecting Human Rights expressed in the Code of Conduct. The Policy is aligned with the requirements of the International Bill of Rights and the ILO Fundamental Conventions and is approved by the Board. This Policy applies to all employees, contractors, and consultants in the Prosafe group (Prosafe SE and its subsidiaries). We expect our suppliers and business partners to respect and adhere to this policy and share our commitment to respect internationally recognized Human Rights and Labour Standards.

Our Code of Conduct, Human Rights and Labour Standards are addressed in Section 2 of our Approved Supplier Verification Questionnaire (ASVQ) and suppliers are asked to confirm acceptance and adherence when managing their own Supply Chains. When contracting with our key suppliers we include our Code of Conduct as part of the Agreement/Contract which is then signed by both parties.

² <https://www.prosafe.com/wp-content/uploads/2024/11/Prosafe-Code-of-Conduct-v2-261124-final.pdf>

³ <https://www.prosafe.com/wp-content/uploads/2024/01/Human-Rights-Policy.pdf>

⁴ <https://freedomhouse.org/explore-the-map?type=fiw&year=2026>

3. Human Rights-related risks in Prosafe's operations

Prosafe operates in the international oil and gas industry which is a strictly regulated industry with a strong presence of trade unions.

In 2025, Prosafe had offices and/or operations in six countries scoring 99, 94, 92, 84, 73, and 48, respectively in the internationally recognised Freedom in the World report⁴ by Freedom House which assesses political rights and civil liberties for 208 countries. The scoring is based on a scale from zero (not free) to 100 (free). The lowest score of 48 is for Singapore and is mainly related to political freedom and civil liberties. Our Singapore activities consist of five employees with wage levels and working conditions on par with Company practice.

Prosafe's approach to respecting Human Rights starts with the Company's commitment to its workforce. This includes ensuring that staff are treated fairly and without discrimination and have a healthy, safe, and secure working environment, in addition to respecting their right to freedom of association and right to negotiate and cooperate through relevant representative bodies.

3.1 Risk of negative consequences for Human rights and Labour Standards

As a global offshore service company operating in harsh environments, our business has inherent risks related to safety, the environment, and potentially Human Rights violations. Prosafe has a zero-mindset philosophy in respect of matters relating to HSSEQ and shall endeavour to minimise risk and harm to personnel, assets, and the environment.

Operations in the North Sea are supported by several European Original Equipment Manufacturers (OEM) that provide equipment, spares, and servicing of critical vessel equipment. Operations are highly regulated in the North Sea and as such the risks for breaches of Human Rights and Labour Standards are deemed lower than in less regulated regions.

Operations in Brazil are predominantly for Petrobras, the state-owned Brazilian multinational energy company. Although risks in Brazil may be perceived higher than in our North Sea operations, we impose the same strict quality requirements to our local suppliers as we do to European OEMs to support our operations in the region. This approach helps maintain standards and safety onboard our vessels in addition to reducing Human Rights risks and contributing to the local industry in a key market for Prosafe.

Prosafe is not directly involved in the extraction of hydrocarbons, our support services are mainly related to the support of the installation, maintenance, and repair of offshore installations for National Oil companies. Given the nature of our business and size of our Supply Chain we have used the UN Guiding Principles on Business and Human Rights to focus on identifying general areas where the risk of potential adverse Human Rights impacts is most significant. The table below identifies potential risks based on the location and type of operations, the use of third-party providers for critical equipment and services, and our key Supply Chain partners required to support safe and efficient operations.

Human Rights	Operational Impact	Mitigation
Employees' right to a healthy and safe work environment and living environment.	We own and operate five (5) vessels, operating in harsh offshore environments, globally. Our vessels are gangway connected to our client's host installation providing accommodation and support services for client contractors 24 hours a day. These operations can be considered safety critical and represent an inherent risk to our shipboard management team and guests. Vessel recycling activities and the use of yards to safely dispose of our assets also present a risk to third party employees right to a healthy and safe working environment.	Safety is our number one priority, and we recognize that we have a responsibility to do what we can to ensure the health and safety of our employees, contractors, and guests. We have a robust HSSEQ policy and detailed procedures that are audited by independent third parties to ensure compliance. In all cases, Prosafe will adhere to relevant conventions (2009 Hong Kong Convention, 1989 Basel Convention), always adopt best practice, provide financial guarantees, and appoint independent recycling yard representation where necessary, until the asset is completely recycled, and conduct extensive diligence when recycling of any asset.
Freedom from forced labour and human trafficking.	We are aware that the marine industry has been exposed to forced labour and people with contracts that are not in line with Human Rights.	We ensure that we follow all local and regional regulations and are externally audited for compliance. We employ most of our crew in Brazil and otherwise use reputable third-party crewing agencies and audit them on their performance and compliance.
Non-discrimination in hiring, employment, pay and benefits.	It is an inherent risk to all businesses, but particularly in our industry which has a particularly strong gender disparity.	We have clear policies and procedures on hiring and employment, and we monitor and ensure fair pay and benefits for all our employees.
Diversity, Equality & Inclusion.	Men have traditionally made up a greater proportion of the recruitment base for offshore operations, and this is reflected in Prosafe's gender breakdown.	Prosafe operates an equal opportunity policy including gender equality. We monitor, analyse and report our employee statistics. We are actively working to ensure the operating and employment environment we create is attractive to women and any current or potential employee, regardless of gender, age, disability, pregnancy and maternity, nationality, religion, or sexual orientation.
Freedom from workplace harassment.	We know there can be friction and disputes between people. We do not accept any form of harassment in any work environment.	We expect all our employees, temporary staff, contractors, consultants and suppliers in the Group to follow our Code of Conduct and Human Rights policy, ensuring freedom from workplace harassment. Employees are encouraged to report any incident as outlined in our Code of Conduct and Whistleblowing Policy.

3.2 Diversity and Equality

We believe that strength lies in differences, not in similarities. Our diverse and talented workforce is one of the Company's most important competitive advantages in satisfying the requirements of our clients. Attracting, developing, and retaining the best employees of all backgrounds gives the Company access to new ideas, promotes better decision-making, and creates a workforce that mirrors our clients and the world at large.

Prosafe operates an equal opportunity policy including gender equality. Men have, however, traditionally made up a greater proportion of the recruitment base for offshore operations, and this is reflected in our gender breakdown.

We aim to offer the same opportunities to all and ensure that there is no discrimination with respect to recruitment, remuneration or promotion, due to gender, age, disability, pregnancy and maternity, nationality, religion, or sexual orientation.

All employees shall have a salary that is seen as fair, competitive and in accordance with industry standards. Only relevant qualifications such as education, experience, performance, and other professional criteria shall be considered when appointing new employees, making performance evaluations, settling remuneration, and awarding promotions.

4. Human Rights-related risks within Supply Chain

4.1 Supplier Due Diligence

During 2024, we implemented the Supply Chain Transparency and Due Diligence Module, developed by Achilles Information Limited which is aligned with international legislations and the conventions defined within the ILO, to provide improved due diligence on our Supply Chain. The questionnaires will provide a basis for us to compare and analyse our suppliers against others in the Oil & Gas industry.

During 2025, a total of 22 suppliers completed the Supply Chain Transparency and Due Diligence Module, compared with 18 the year before. The vast majority of these suppliers have adequate policies in place covering areas such as health and safety and human rights. Some have been marked for follow up in certain areas.

Overall, the selected Prosafe Suppliers (22 suppliers) have a higher rating than the average scoring across all metrics compared to the total sample of suppliers mapped by Achilles (25,156) and the 3,567 suppliers mapped by Achilles within the global energy space (the maximum score is 100).

We will continue to work with Achilles to evaluate and monitor our Supply Chain.

4.3 Risk Assessment

Prosafe has undertaken a preliminary risk assessment focusing on key suppliers of people-related services such as crewing providers/ medical providers and OEMs that provide us with service engineers

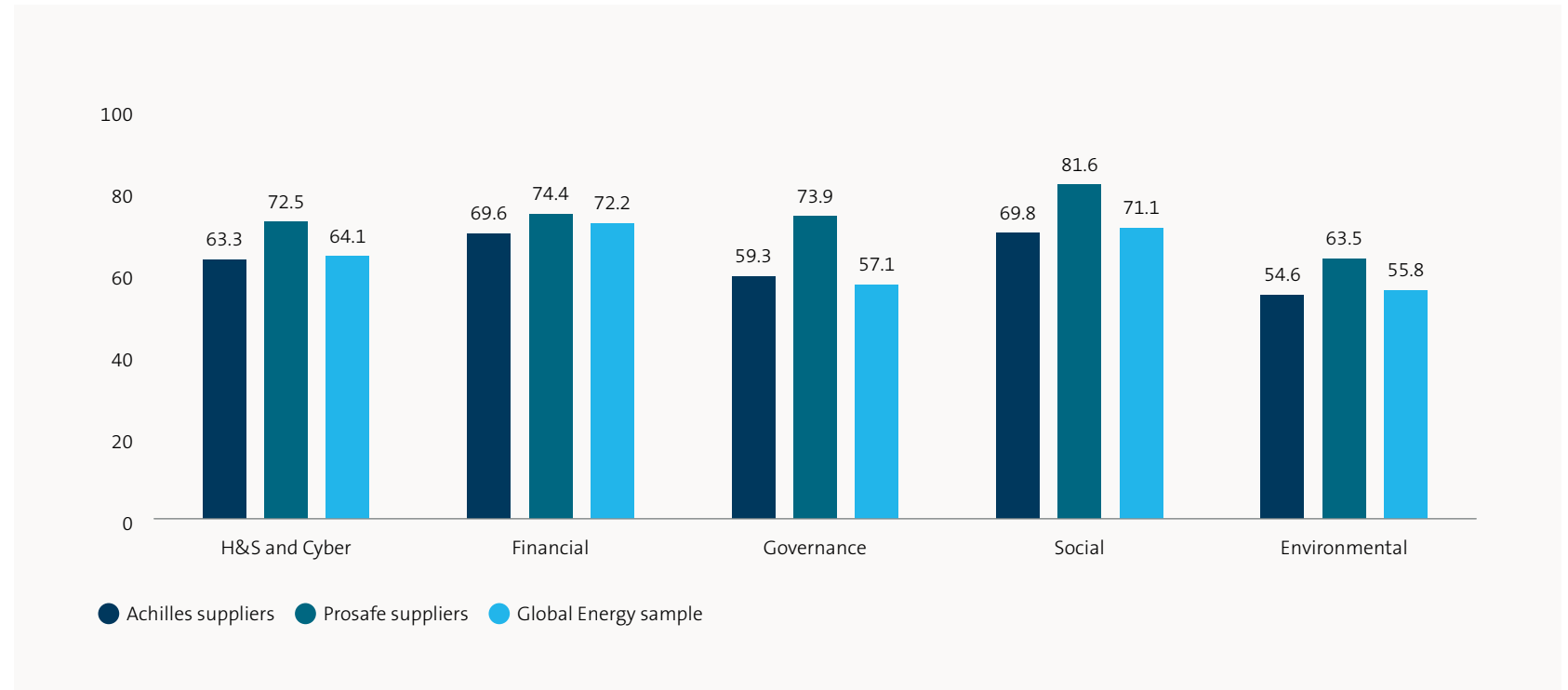

in regions that are deemed higher risk. The risk assessment is based on the following:

- Type of goods/services with a special focus on whether they provide manpower as part of the service
- Location of service requirement
- Perceived risk in the region of operation
- The total annual spend
- Relationship and track record with Prosafe

Description of service provision	Potential negative impact	Action required
<p>Marine and Agency Personnel Services</p> <p>Third-party crewing providers that supply personnel to support our operations in regions that are deemed higher risk.</p>	<p>Potential for agency crew to be exposed to forced labour or have contracts that are not in line with Human Rights standards.</p>	<p>Contracts are in place for key crewing agencies.</p> <p>Transparency & Due Diligence questionnaires will be sent to agencies that provide services in these regions. Crewing providers based in Australia, the UK and Norway are deemed to be low-risk and are not required to complete the questionnaires at this time.</p> <p>Review results from questionnaire and determine if further action is required.</p>
<p>Catering Providers</p> <p>Third-party catering providers that supply catering crew, food and cleaning products to support our operations.</p> <p>Prosafe's clients often contract and manage the catering service provision in-house. In this instance Prosafe is not responsible for providing the service. In Brazil, the catering provision for our vessels on charter with Petrobras are provided by the state-owned Oil Company.</p>	<p>Potential for catering crew to be exposed to forced labour or have contracts that are not in line with Human Rights standards.</p> <p>Potential that food is not sourced in an ethical and responsible manner, meeting local and national standards, where necessary.</p>	<p>Contracts are in place for key catering providers.</p> <p>Transparency & Due Diligence questionnaires will be sent to relevant providers. Audits are common practice to measure performance and compliance.</p> <p>Location of operations may require additional due diligence/audits depending on perceived risk in the region.</p> <p>Review results from the questionnaire and determine if further action is required.</p>
<p>Global Medical Services Provider</p> <p>Third-party provider offering shoreside support and offshore medics in all regions of operations, if requested by our clients. Focus on regions that are deemed higher risk, including Brazil and USA.</p>	<p>Potential for offshore Medics/Doctors to be exposed to forced labour or have contracts that are not in line with Human Rights standards.</p>	<p>Contract in place with global provider. Transparency & Due Diligence questionnaire will be issued to the service provider with a focus on the supply of medics/medical services in high-risk regions.</p> <p>Review results from the questionnaire and determine if further action is required.</p>
<p>Original Equipment Manufactures</p> <p>Key Suppliers that maintain safety critical equipment onboard our vessels. Many of these providers are based in Europe but have established operations in higher-risk regions, including Brazil and USA</p>	<p>Potential for OEM service engineers to be exposed to forced labour or have contracts that are not in line with Human Rights standards.</p>	<p>Contracts are often in place with key suppliers. Transparency & Due Diligence questionnaire to be issued to providers that have a local presence in high-risk regions of operations.</p> <p>Review results from the questionnaire and determine if further action is required.</p>
<p>Non-OEM Suppliers Brazil</p> <p>Key suppliers in the Brazil region that provide services onboard our vessels supporting our operations.</p>	<p>Potential for service engineers to be exposed to forced labour or have contracts that are not in line with Human Rights standards.</p>	<p>Key local suppliers in Brazil that often provide us with offshore service personnel to support our operations.</p> <p>Transparency & Due Diligence questionnaire to be issued to providers that have a local presence in high-risk regions of operations.</p> <p>Review results from the questionnaire and determine if further action is required.</p>

5. Human Rights due diligence within Prosafe

As a responsible business we continue to develop our due diligence processes to meet our obligations, but we also recognise that there is more we can do to improve. We have made further progress in 2025 and plan to develop, evaluate and improve our Human Rights due diligence further in the year ahead.

5.1 Guidelines and routines for handling Human Rights due diligence

Prosafe has prepared an action plan that will guide the company on its path to compliance with the requirements found in the Transparency Act.

Action	Status	Comment
Anchor accountability in the Board of Directors	✓	The ultimate responsibility for complying with the Transparency Act, and Human Rights lies with Prosafe's Board of Directors. Human Rights policy was implemented in 2022 to demonstrate our commitment.
Launch a stand-alone Human Rights Policy	✓	
Anchor in the Internal Management System (IMS)	✓	Procurement and Supply Chain Management documentation has been updated to include references to Human Rights due diligence. ASVQ has been updated in the Integrated Management System.
Additional questions about Human Rights and Labour Standards included in the company's Approved Supplier Verification Questionnaire	✓	Completed and updated in the Integrated Management System
Build employee awareness and competence by the rollout of an e-learning program with a focus on human rights and labour standards	✓	E-learning course "Respecting Human Rights" has been rolled out and is required to be completed by all Prosafe employees and third party/ agency employees.
Update requirements to suppliers and business associates	✓	
Map suppliers and business associates	✓	Ongoing process for existing and new Suppliers.
Perform supplier risk assessment in line with OECD guidelines	—	Ongoing process for existing and new suppliers.
Perform Supplier audits focusing specifically on Human Rights and Labour Standards.	✓	We have included more detailed questions relating to Human Rights and Labour Standards in our annual Supplier Audits. We will continue to develop this further in 2026.
Initiate required actions to stop, prevent or reduce any negative impact or damage	✓	Will be initiated based on the results of the Transparency & Due Diligence questionnaire and/or supplier audits.
Monitor implementation and results	✓	Actions can be defined and tracked following supplier audits/ recommendations
Report in the annual ESG report	✓	

5.2 Improving the identification of Human Rights risks within Supply Chain

We have updated our Approved Supplier Verification Questionnaire (ASVQ) to include additional questions relating to Human Rights and Labour Standards to improve our supplier due diligence process and help identify potential risks within our Supply Chain. In addition, we also use several oil and gas industry-led Joint Qualification Systems (JQS) to support the prequalification of our suppliers.

We currently use the following JQS providers depending on the region of operations:

- Achilles FPAL⁵ – UKCS & Brazil
- Suricatta – Brazil
- SEQual⁶ – UKCS
- Magnet JQS⁷ – NCS
- Achilles FPAL – Australia

While the focus of the JQS is HSSEQ performance and standards, it is evident that providers are starting to develop their systems to include social aspects, including Human Rights and auditing specifically in this area.

⁵ <https://www.achilles.com/community/oil-and-gas>

⁶ <https://sequal.co.uk>

⁷ <https://magnetjqs.com>

⁸ <https://prosafe.integrity.complylog.com>

5.3 Human Rights protections in contract terms and conditions

Prosafe completed a legal review of standard supplier terms and conditions in 2022 and include several clauses to meet the obligations regarding the Norwegian Transparency Act. These clauses give us the right to audit suppliers at any time for the purpose of ensuring and confirming compliance with all Human Rights Protection Legislation. In addition, we include a clause for termination should a supplier breach any applicable laws, or we have reasonable grounds to believe that the supplier has breached any applicable laws.

5.4 Incident reporting

Prosafe has a secure Whistleblowing channel, IntegrityLog⁸ an easy online tool that allows safe, anonymous reporting of business integrity concerns. The whistleblowing channel allows anyone to report breaches or suspected breaches of our Code of Conduct, Governing Policies or Laws and Regulations.

Stakeholders are encouraged to make a report in relation to business integrity concerns including:

- Breaches of our Code of Conduct or other governing policies
- Violations of Human or Labour rights
- Breaches of applicable laws and regulations
- Incidents of corruption, bribery and/or facilitation payments
- Incidents of fraud or theft
- Incidents of discrimination or harassment
- Threats to life or health
- Insider trading
- Inappropriate gifts or gratuities

Individuals raising concerns retain the right to remain anonymous provided that (i) the Company will not be in breach of any applicable law, rule, or regulation by maintaining the anonymity and (ii) the issue raised does not concern a criminal offence. Notifications on IntegrityLog will be received, processed, and followed up by an independent third party.

All concerns reported will be treated confidentially. Prosafe will ensure that no retaliation is taken against a whistleblower and that reports made in good faith will have no effect on their career.

In 2025, there were six whistleblowing cases, all relating to employee relations and of minor seriousness. All cases have been reported to the Human Resources department and have been closed.

5.5 Response to Human Rights or Labour Standards violations

No legal claims have been received from any employee in respect of any violation of Human Rights or Labour Standards, and no breaches of the Code of Conduct in relation to Human Rights or Labour Standards have been observed in 2025. As no Human Rights or Labour Standard incidents were identified, Prosafe has not been involved in providing or enabling remedy during this reporting period. Should such incidents be identified, Prosafe would provide and facilitate remedy.

Prosafe, 30 April 2026

For the Board of Directors of Prosafe SE:

Carey Lowe Chair	Jean-Baptiste De Boissieu Deputy Chair	Monique Fares Non-executive Director
Grethe Kristin Moen Non-executive Director	Knut Bø Non-executive Director	Reese McNeel Chief Executive Officer

For the Board of Directors of Prosafe AS:

Halvdan Kielland Chair	Reese McNeel Board member	Yennie Feng Board member
---------------------------	------------------------------	-----------------------------

For the Board of Directors of Prosafe Offshore Pte Ltd:

Reese McNeel Chair	Halvdan Kielland Board member
-----------------------	----------------------------------

For the Board of Directors of Prosafe Rigs Pte Ltd:

Reese McNeel Chair	Halvdan Kielland Board member
-----------------------	----------------------------------

For the Board of Directors of Prosafe Offshore Ltd:

Ryan Stewart Board member	Reese McNeel Board member
------------------------------	------------------------------



Prosafe

Accommodating
the Offshore
Industry

www.prosafe.com